

# Kiosk Card Printer

from NBS Technologies

## Javelin® Kiosk

The NBS Multiple Hopper Kiosk card printer is designed for applications requiring self-service instant issuance of personalised plastic cards. With up to 8 hoppers the NBS Kiosk is flexible with easy integration to create a cost effective and innovative kiosk.

NBS Kiosk offers an all in one solution with high quality full colour and monochrome printing single or dual sided with included reject function to retrieve defective and uncollected cards. The kiosk is also fully supported for any requirement of encoding. The high capacity and flexible multi hopper options minimise maintenance cost and time and maximise the kiosk application.

The metal structure and dust protection cover make this unit not only very robust and durable but also extremely reliable with a low cost of ownership.

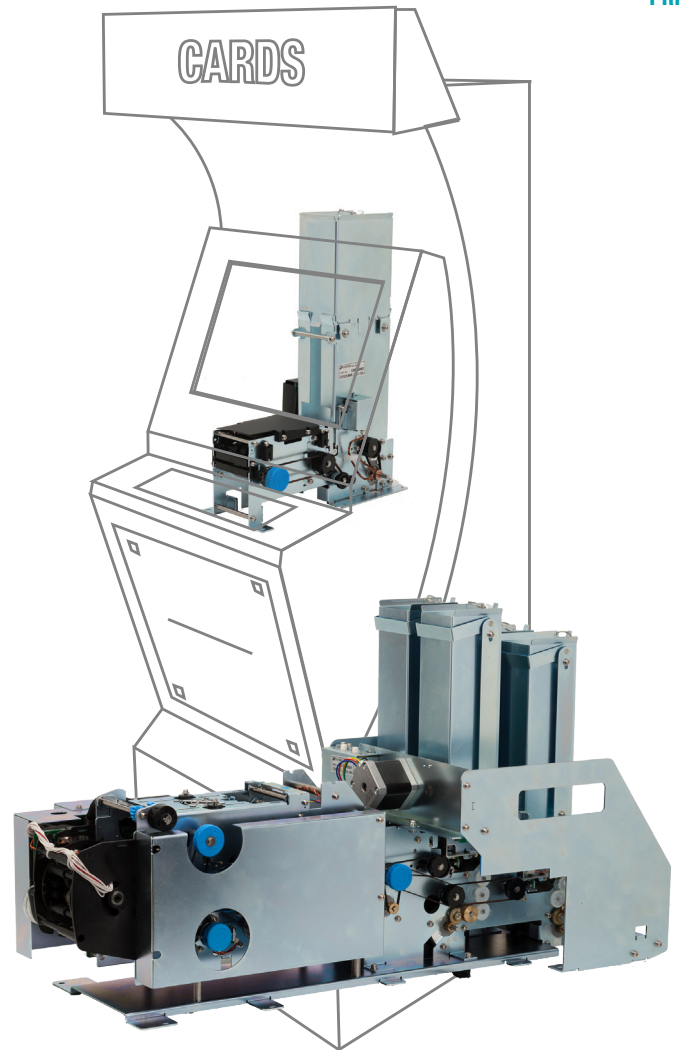

**IDEAL FOR INSTANT ISSUANCE OF BANK CARDS, MEMBERSHIP CARDS, LOYALTY OR GIFT CARDS, TRANSIT CARDS, STUDENT CARDS, PREPAID CARDS, CASINO/GAMING CARDS**

### THE JAVELIN® KIOSK OFFERS THESE KEY FEATURES AND BENEFITS:



#### FLEXIBLE

- Single and multi tray hopper options
- 3 x capacity of card hopper – 150, 250 or 500 cards
- Supports multiple encoding options
- Ethernet as standard



#### DURABLE

- Metal structure
- Dust protection cover
- High volume card printing and dispensing



#### EASY-TO-USE

- Detachable card hoppers
- Low card alert
- LCD display for print status
- One USB interface
- Software package – Driver, DLL, Data Transmission Protocol

CONSULTING

SOFTWARE

HARDWARE

SMART CARD MANUFACTURING



Total  
Card Solutions

WWW.NBSTECH.COM

## Printer Specifications

<b>Print Mode</b>	Single or dual sided, unit is dual sided as standard
<b>Print Method</b>	Thermal transfer (mono), Dye-sublimation (colour)
<b>Print speed</b>	Mono: 6 sec/card, YMCKO: 23 sec/card (single-side) YMCKOK: 31 sec/card (dual-side)
<b>Ribbons</b>	KrO: 500 prints/roll, YMCKO: 250 prints/roll, YMCKOK: 170 prints/roll, Half-panel YMC plus full-panel KO: 400 prints/roll Monochrome: black, silver, gold, red, blue, white, scratch-off: 1000 prints/roll
<b>Card encoding options</b>	Magnetic Stripe: ISO7811 (tracks 1, 2, 3); Hi-Co/Lo-Co, Head life - 4,000,000 passes Contact (IC): ISO 7816, EMV, PC/SC, IC contact life: 1,000,000 passes Contactless (RF): MiFare, ISO 14443 A,B, ISO15693
<b>Warranty</b>	12 months
<b>Printer interfaces</b>	USB 2.0; internal USB hub to connect peripheral devices; built-in Ethernet (10/100Mps) network
<b>Software drivers</b>	Windows 2000, XP, Server 2003/2008, Vista, Windows 7, Windows 8
<b>Fonts/Images</b>	300 dots per inch (11.8 dots per mm) resolution, 16.7 million colours True Type fonts via Windows drivers
<b>Barcodes</b>	Code 39, Code 128 B & C with & without check digit, 2 of 5 interleaved, UPC-A, EAN 8 & EAN 13 PDF-417 2D barcode and other symbols can be printed via Windows® drivers
<b>Card capacity</b>	150 – 4000 cards depending on configuration each hopper capacity 150,250, 500 cards
<b>Power source</b>	Input: 100V - 240V, 50/60Hz; Output: DC 24V (FCC Class B, CE and UL & CUL approved)
<b>CPU &amp; RAM</b>	CPU: 32 bit processor RAM: 128MB
<b>Environment</b>	Operating temperature: 0 - 50°C / 32 - 122°F, 20 - 90% RH Storage temperature: -25 - 70°C / -13 - 158°F

## Card Specifications

<b>Types</b>	PVC & composite PVC
<b>Card width/length</b>	ISO CR-80-ISO 7810: 53.98mm (W) x 85.60mm (L)
<b>Card thickness</b>	0.5mm - 1.2mm

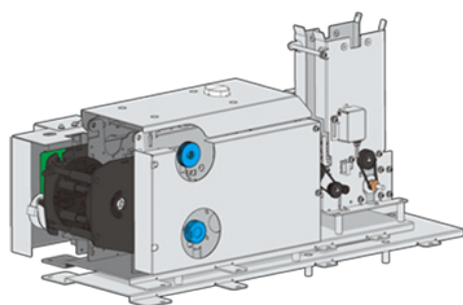

**Single Card Hopper**

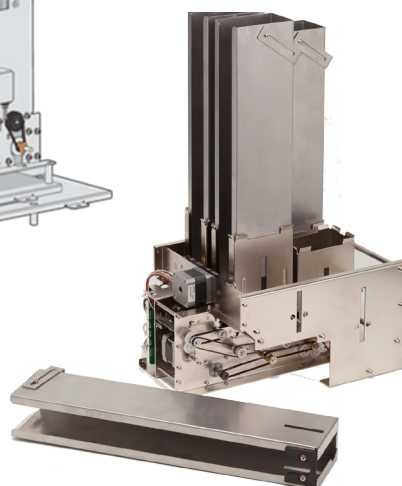

**Removable Card Hoppers**

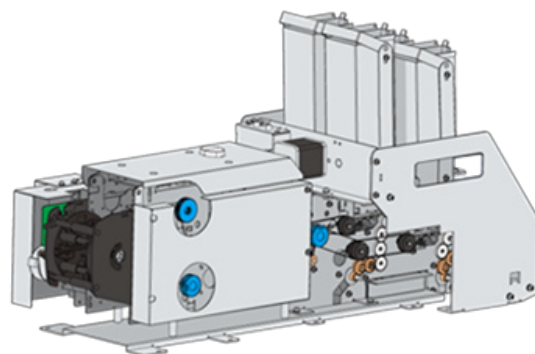

**Multiple Card Hoppers- 2/4/8 hoppers**



w: [www.nbstech.com](http://www.nbstech.com)  
e: [info@nbstech.com](mailto:info@nbstech.com)

Corporate Headquarters  
Canada  
703 Evans Avenue  
Toronto, Ontario  
M9C 5E9  
Canada  
tel: +1 416.621.1911  
fax: +1 416.621.8875

Contact our NBS card personalization experts for full details on this and other card personalization products at:

Europe, Middle East, Africa  
B1 Moorfield Point  
Slyfield Industrial Park  
Guildford, Surrey GU1 1RU  
United Kingdom  
tel: +44 (0)1483 563200  
fax: +44 (0)1483 511189

North / South America  
10925 Bren Road E  
Minneapolis, MN 55343  
USA  
tel: +1 416.840.8620  
fax: +1 952.912.9439

Asia Pacific  
PO Box 780  
Hurstville BC  
NSW 1481  
Australia  
tel: +61 (2) 9546 6841  
fax: +61 (2) 9546 6851

